

SERVICE REPAIR

MANUAL

Hyster D114 (E25XM2, E30XM2, E35XM2, E40XMS2) Forklift

HYSTER

STEERING SYSTEM FOR ELECTRIC LIFT TRUCKS

A1.00-1.50XL (A20-30XL) [A203]; J2.00-3.00XL (J40-60XL) [B168];
E1.25-1.75XL (E25-35XL) [C114]; E2.00-3.00XL (E40-60XL) [C108];
E3.50-5.50XL (E70-120XL, E70-120XL₃) [C098];
E1.50-2.00XMS (E25-40XMS, E25-40XM₂S) [D114];
E2.00-3.20XM (E45-65XM, E45-65XM₂) [F108];
J2.00-3.20XM (J40-60XM, J40-60XM₂) [A216];
N30XMH, N30XM₂H [A210, C210]

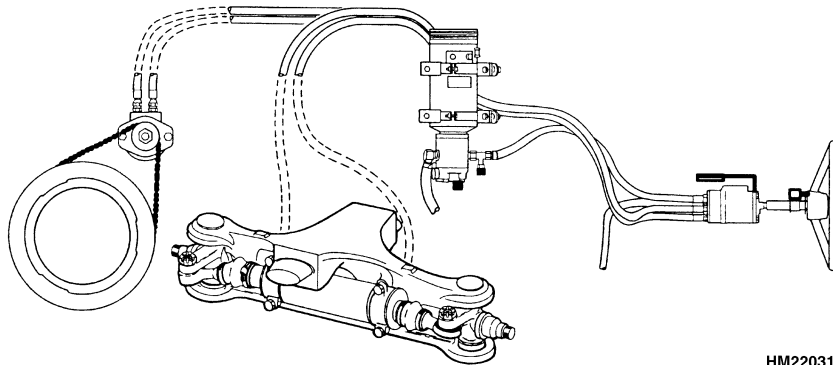

HM220314

HYSTER

SAFETY PRECAUTIONS

MAINTENANCE AND REPAIR

- When lifting parts or assemblies, make sure all slings, chains, or cables are correctly fastened, and that the load being lifted is balanced. Make sure the crane, cables, and chains have the capacity to support the weight of the load.
- Do not lift heavy parts by hand, use a lifting mechanism.
- Wear safety glasses.
- **DISCONNECT THE BATTERY CONNECTOR** before doing any maintenance or repair on electric lift trucks.
- Disconnect the battery ground cable on internal combustion lift trucks.
- Always use correct blocks to prevent the unit from rolling or falling. See **HOW TO PUT THE LIFT TRUCK ON BLOCKS** in the **Operating Manual** or the **Periodic Maintenance** section.
- Keep the unit clean and the working area clean and orderly.
- Use the correct tools for the job.
- Keep the tools clean and in good condition.
- Always use **HYSTER APPROVED** parts when making repairs. Replacement parts must meet or exceed the specifications of the original equipment manufacturer.
- Make sure all nuts, bolts, snap rings, and other fastening devices are removed before using force to remove parts.
- Always fasten a **DO NOT OPERATE** tag to the controls of the unit when making repairs, or if the unit needs repairs.
- Be sure to follow the **WARNING** and **CAUTION** notes in the instructions.
- Gasoline, Liquid Petroleum Gas (LPG), Compressed Natural Gas (CNG), and Diesel fuel are flammable. Be sure to follow the necessary safety precautions when handling these fuels and when working on these fuel systems.
- Batteries generate flammable gas when they are being charged. Keep fire and sparks away from the area. Make sure the area is well ventilated.

NOTE: The following symbols and words indicate safety information in this manual:



WARNING

Indicates a condition that can cause immediate death or injury!



CAUTION

Indicates a condition that can cause property damage!

TABLE OF CONTENTS

General	1
Description	3
Steering Wheel and Column Assembly Repair	4
Assembly Components, Remove	4
Assembly Components, Install	9
Power Steering Motor and Pump	12
Description	12
Remove and Disassemble, Models E1.25-3.00XL (E25-60XL), J2.00-3.00XL (J40-60XL), E2.00-3.20XM (E45-65XM, E45-65XM ₂), N30XMH, and N30XM ₂ H,	14
Remove and Disassemble, Models E3.50-5.50XL (E70-120XL, E70-120XL ₃)	17
Remove and Disassemble, Models J2.00-3.20XM (J40-60XM, J40-60XM ₂)	18
Remove and Disassemble, Models A1.00-1.50XL (A20-30XL)	19
Remove and Disassemble, Models E1.50-2.00XMS (E25-40XMS, E25-40XM ₂ S)	19
Assemble and Install - All models with a vertical mount except J2.00-3.20XM (J40-60XM, J40-60XM ₂)	20
Assemble and Install, Models J2.00-3.20XM (J40-60XM, J40-60XM ₂)	20
Assemble and Install, Models E1.50-2.00XMS (E25-40XMS, E25-40XM ₂)	21
Power Steering Pump, Repair	21
Seal, Replace	23
Hydraulic Steering Motor	23
Description	23
Hydraulic Steering Motor Repairs	24
Remove	24
Disassemble	24
Clean and Inspect	26
Assemble	26
Install	27
Steering System Air Removal	27
Steering Pressure Check	27
Steering Chain Tension Check (Unit With MDU Only)	28
Optical Encoder and Activator Circuits Check	29
Troubleshooting	31

This section is for the following models:

A1.00-1.50XL (A20-30XL) [A203];
 J2.00-3.00XL (J40-60XL) [B168];
 E1.25-1.75XL (E25-35XL) [C114];
 E2.00-3.00XL (E40-60XL) [C108];
 E3.50-5.50XL (E70-120XL, E70-120XL₃) [C098];
 E1.50-2.00XMS (E25-40XMS, E25-40XM₂S) [D114];
 E2.00-3.20XM (E45-65XM, E45-65XM₂) [F108];
 J2.00-3.20XM (J40-60XM, J40-60XM₂) [A216];
 N30XMH, N30XM₂H [A210, C210]

**Thanks very much for your reading,
Want to get more information,
Please click here, Then get the complete
manual**

JustClickHere 

NOTE:

**If there is no response to click on the link above,
please download the PDF document first, and then
click on it.**

**Have any questions please write to me:
admin@servicemanualperfect.com**

**"THE
QUALITY
KEEPERS"**

**HYSTER
APPROVED
PARTS**

General

There are two different steering systems available: Power Steering and Power Steering with On-Demand. The difference in the components for each system can be found in Figure 1 and Figure 2. This section covers the description, disassembly, assembly, checks, adjustments, and the troubleshooting of the steering system. There is a description for each part of the steering system at the beginning of each repair section. On units with three wheels, the steering system turns the Master Drive Unit (MDU) to steer the lift truck. On units that have four wheels and a steering axle, the steering system operates the steering cylinder to steer the lift truck.

Additional information for the components of the steering system is found in the **Master Drive Unit**

630 SRM 363 which contains the description and repair of the MDU for the A1.00-1.5.XL (A20-30XL), the **Steering Axle** for your unit, and the **Steering Control Unit** for your lift truck model.

A modification has been made in the manifold assembly of the steering control unit used in the A1.00-1.50XL (A20-30XL) trucks that is different than the unit described in the **Steering Control Unit** 1600 SRM 54. The four hydraulic ports are in the bottom of the steering control unit. These ports connect to the four hydraulic hoses for the steering system. The four hydraulic ports on the side of the steering control unit are not used.

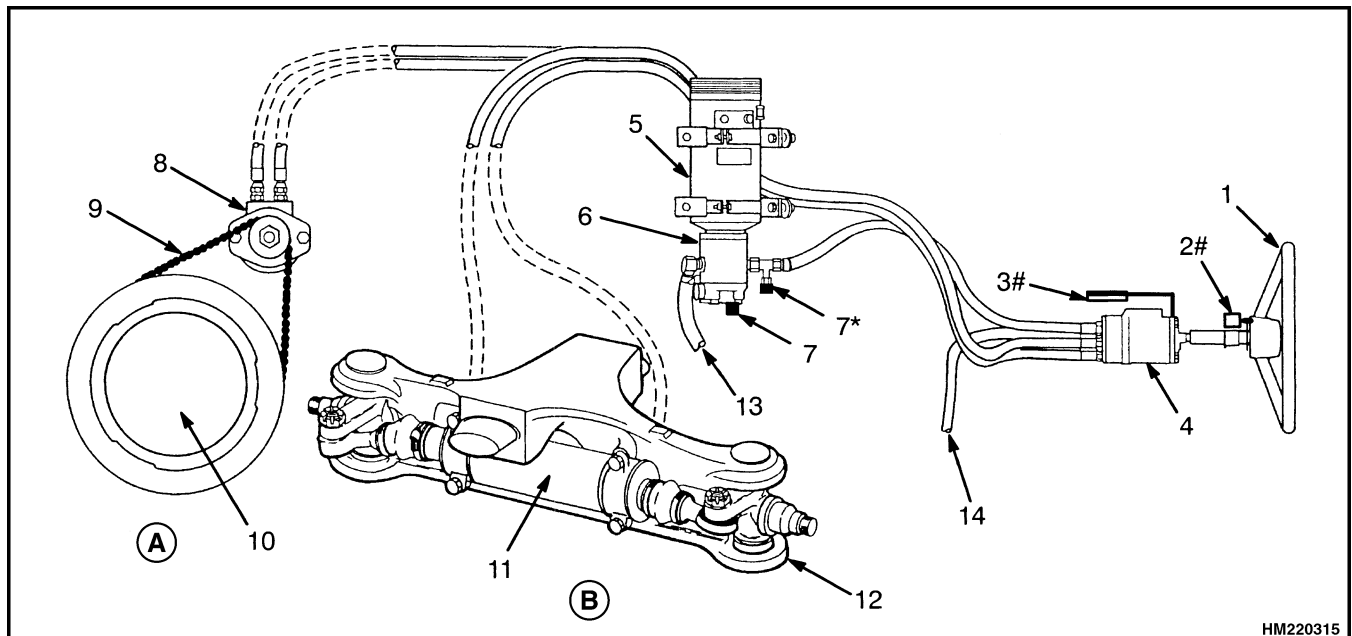

A. THREE WHEEL UNITS

1. STEERING WHEEL
2. OPTICAL ENCODER
3. ACTIVATOR
4. STEERING CONTROL UNIT
5. STEERING PUMP MOTOR
6. STEERING PUMP
7. PRESSURE SWITCH [EXCEPT A1.00-1.50XL (A20-30XL)]

B. MANY FOUR WHEEL UNITS

8. HYDRAULIC STEERING MOTOR
9. STEERING CHAIN
10. MASTER DRIVE UNIT
11. STEERING CYLINDER
12. STEERING AXLE
13. FROM TANK
14. TO TANK

*E3.50-5.50XL (E70-120XL, E70-120XL₃) ONLY.

#POWER STEERING WITH ON-DEMAND ONLY.

Figure 1. Power Steering Components

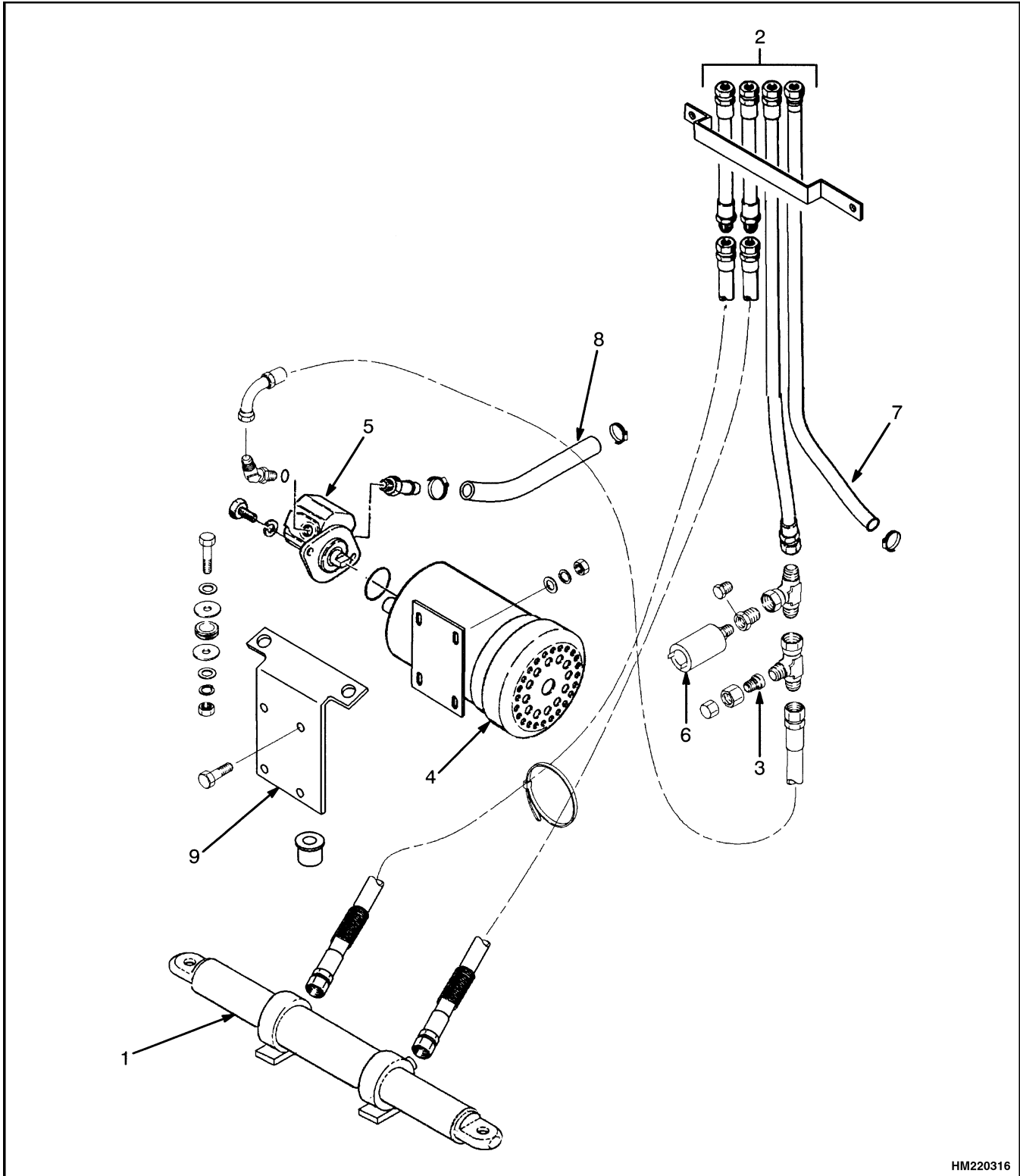

HM220316

Figure 2. Power Steering Components E1.50-2.00XMS (E25-40XMS, E25-40XM₂S)

Legend for Figure 2

- | | |
|-----------------------------|--|
| 1. STEERING CYLINDER | 6. PRESSURE SWITCH (ON-DEMAND STEERING ONLY) |
| 2. TO STEERING CONTROL UNIT | 7. RETURN TO HYDRAULIC TANK |
| 3. PRESSURE CHECK FITTING | 8. FROM HYDRAULIC TANK |
| 4. PUMP MOTOR | 9. MOUNT FOR STEERING MOTOR |
| 5. STEERING PUMP | |

Description

The steering system used on these lift trucks is a hydraulic system that does not have a mechanical connection between the steering wheel and the MDU or steering axle. The control of the steering is through a hydraulic circuit. See Figure 1 and Figure 3. An electric motor drives a hydraulic pump. To energize the motor, the key switch must be **ON** and the seat switch must be closed. When the key switch is *first* moved to the **ON** position, forward or reverse direction must also be selected for the steering system to operate. After the starting sequence is completed, the electric motor on the Power Steering pump will run continuously. The pump motor with the On-Demand system will operate only when the

steering wheel is turned. When the electric motor operates the pump, hydraulic oil flows through the power steering system.

When the steering wheel is rotated to steer the lift truck, the hydraulic oil is routed to the steering motor at the MDU or to the steering cylinder on units with a steering axle. There is a delay between the last rotation of the steering wheel and the system deenergizing in the Power Steering with On-Demand system. This delay keeps the system operating when the operator is not turning the steering wheel during straight travel. The delay is approximately 1 second on some truck models to between 4 and 5 seconds on other models.

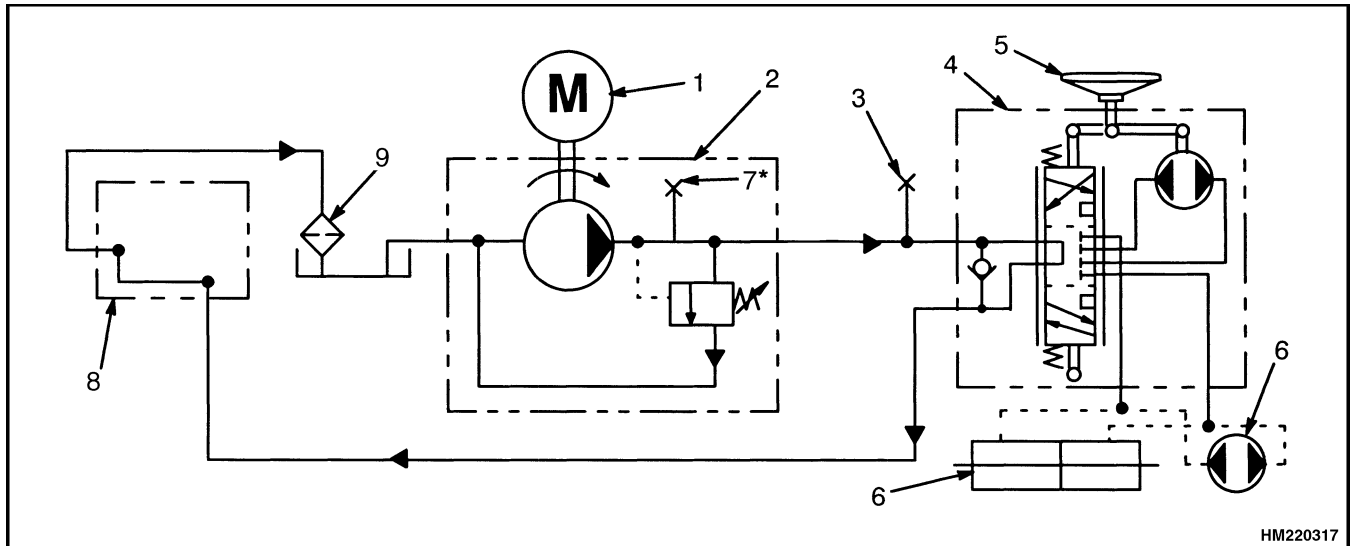

- | | |
|--------------------------|-------------------------------|
| 1. MOTOR | 6. STEERING CYLINDER OR MOTOR |
| 2. STEERING PUMP | 7. PRESSURE TEST PORT* |
| 3. PRESSURE TEST PORT | 8. HYDRAULIC TANK |
| 4. STEERING CONTROL UNIT | 9. FILTER |
| 5. STEERING WHEEL | |

*PRESSURE SWITCH FOR ON-DEMAND STEERING OPTION ONLY. REPLACES CHECK PORT.

Figure 3. Steering System Hydraulic Schematic

A gear on the shaft of the steering wheel drives the gear of the optical encoder as the steering wheel is moved to steer the lift truck. The optical encoder sends a signal to the activator. The activator completes the battery negative circuit for the steering contactor to energize the steering pump motor. See Figure 4 and Figure 19 for the electrical connections for Power Steering with the On-Demand system. Also see **Diagrams** section for your unit. The steering control unit is also operated by the steering wheel to direct oil to the steering cylinder or hydraulic motor.

NOTE: On units with a steering axle, there is a pressure switch in the hydraulic circuit. Any time the system is operational and the system pressure is above 2.07 kPa (0.3 psi), the switch energizes the contactor for the steering pump motor. This pressure switch allows the system to continue to operate even if the steering wheel is not moving.

Units that have On-Demand steering have an optical encoder circuit. A gear on the shaft of the steering wheel moves the gear of the optical encoder when the steering wheel is moved. See Figure 4, Figure 6 and Figure 7. The optical encoder sends a signal to the activator assembly. The activator assembly completes

the battery negative circuit for the steering contactor to energize the steering pump motor. The steering wheel also operates the steering control unit. When the steering wheel is rotated to steer the lift truck, the hydraulic oil is sent to the steering cylinder on the steering axle.

The steering control unit is a rotary valve operated by the steering wheel. During the steering operation, the steering control unit controls the direction of flow and volume of oil to control the direction and degree of turn. On units with an MDU, the hydraulic motor has a sprocket on the output shaft that rotates the MDU by a steering chain. On units that have a steer axle, the steering cylinder moves the steering linkage to move the steer wheels. Hydraulic oil returns from the hydraulic motor or cylinder to the steering control unit and then returns to the hydraulic tank.

If for any reason the steering pump does not operate, a check valve permits the steering control unit to still control the steering system. The lift truck is difficult to steer when the steering pump is not operating, but the steering control unit can operate the hydraulic motor or steering cylinder and makes steering possible.

Steering Wheel and Column Assembly Repair

The upper end of the steering shaft has splines for the steering wheel. A large nut holds the steering wheel onto the steering shaft. The horn button is the cover for the center of the steering wheel. The lower end of the steering shaft has splines or a tang to engage the steering control unit. A push rod allows the horn button to actuate the horn switch. See Figure 4, Figure 5, Figure 6 and Figure 7.

The steering column is adjustable and is held in position by a latch. The steering column position can be changed for different operators. The steering column must be raised to the **UP** position to provide clearance for the seat when removing or installing the battery. There is a cover on the steering column for access to the steering control unit, key switch, horn switch, direction switch (if installed), optical encoder, and on some units, the activator. The activator on many of the **XM** units is under the instrument panel to the left of steering column.

ASSEMBLY COMPONENTS, REMOVE

NOTE: See the section, **Steering Control Unit** for your unit for the correct repair procedures for the steering control unit.

NOTE: This procedure is for the removal of all components of the steering column assembly. Usually it is not necessary to remove all of the components. Do only those steps of the procedure necessary to remove the component you need to remove.

1. Disconnect the battery and attach a tag on the truck battery connector, stating **DO NOT CONNECT BATTERY**. Raise the steering column to the **UP** position. Remove the access cover from the steering column.
2. Remove the housing of the steering column. Remove key switch. Make an identification of the electrical wires and disconnect them from the key switch.

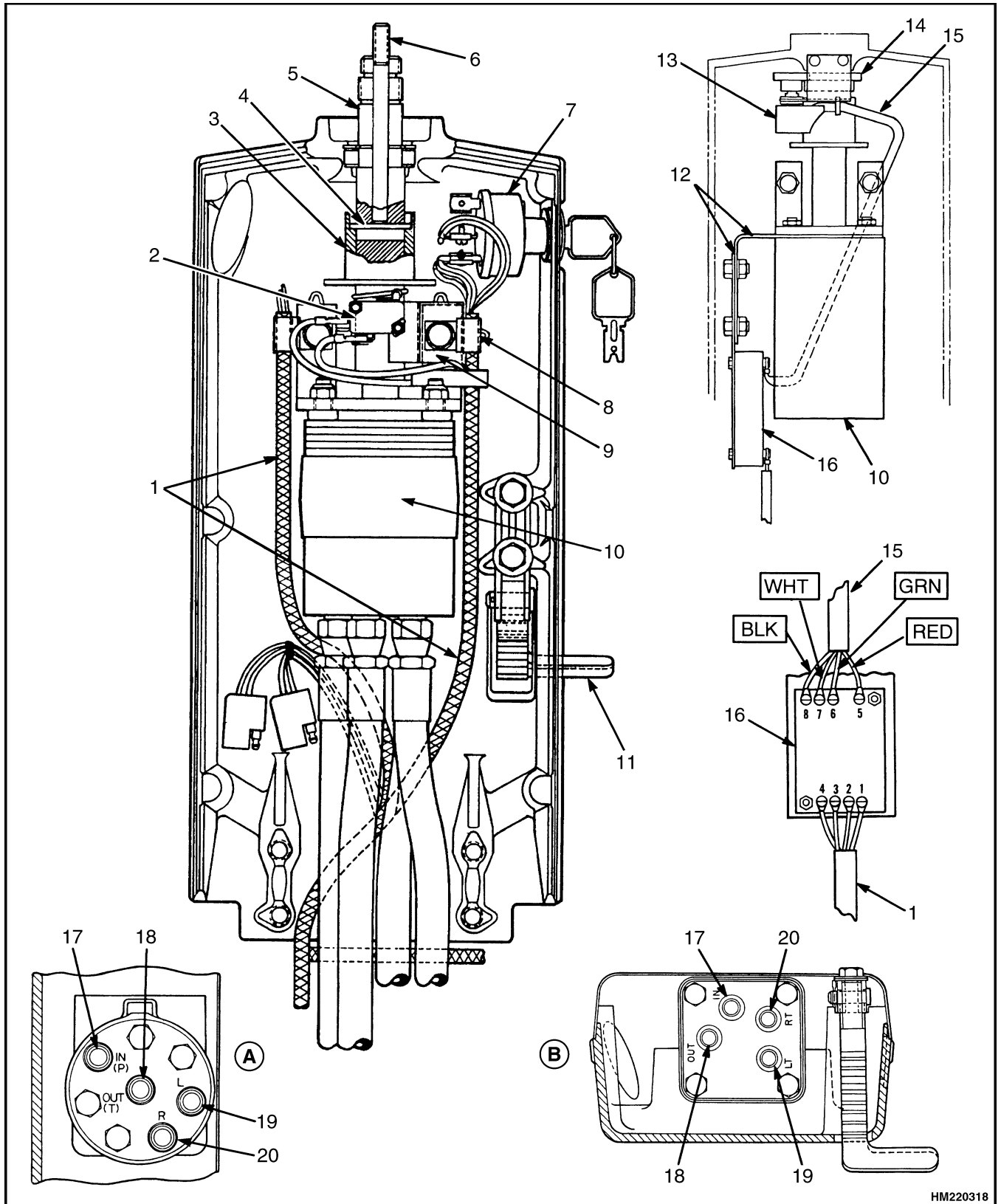

Figure 4. Steering Wheel and Steering Column Assembly (Early XL Units)

Legend for Figure 4

NOTE: FOR CORRECT CONNECTION, SEE THE **DIAGRAMS** SRM FOR YOUR LIFT TRUCK.

A. DANFOSS

1. TRUCK WIRE HARNESS
2. SNAP RING
3. PLASTIC TUBE
4. PIN
5. STEERING SHAFT
6. SOCKET HEAD SCREW
7. KEY SWITCH
8. CLAMP
9. BRACKET
10. STEERING CONTROL UNIT

B. TRW

11. LATCH
12. BRACKET
13. OPTICAL ENCODER AND BRACKET
14. DRIVE GEAR AND SETSCREW
15. ENCODER/ACTIVATOR WIRE HARNESS
16. ACTIVATOR
17. INPUT
18. OUTPUT
19. LEFT TURN
20. RIGHT TURN

3. Remove the instrument display panel or instrument display meters and gauges. Early model lift trucks can have either an instrument display cluster that wraps around the steering column, near the steering wheel, or instrument display meters and gauges that are located on both sides of and near the bottom of the steering column. See the service manual sections **Instrument Cluster, Instrument Panel Indicators and Senders** or **Electrical System** for your lift truck model for the removal procedures.

4. For later model lift trucks, the display panel is located on the cowl, or steering column housing, to the right of the steering column assembly. Disconnect all plugs connected to the display panel.

5. If installed, remove the handle, boot, and large nut that fasten the direction switch. Remove the direction switch from the housing of the steering column. Make an identification of the electrical wires and disconnect them from the direction switch.

6. Remove the capscrew that fastens the bracket for the horn switch to the housing of the steering column. Move the horn switch and bracket away from the steering column.

7. Remove the horn cover, snap ring, and base plate (not part of Petri steering wheel). Lift the push rod and adjuster spool out the top of the steering

shaft. Remove the large hex nut and remove the steering wheel from the shaft. A puller makes removal of the steering wheel easier, but not all steering wheels have puller holes.

8. If the lift truck has On-Demand steering, remove the optical encoder and activator and the brackets. See Figure 4, Figure 6, and Figure 7. It is not necessary to remove the activator if it is not in the steering column. See Make an identification of the electrical wires and disconnect them from the assemblies.

9. Make an identification of the hydraulic hoses at the steering control unit so they can be connected correctly during assembly. Some hoses have swivel fittings to permit disconnecting at the steering control unit. Disconnect the other hoses at the base of the cowl, the control valve, or the steering pump. Remove all mounting clamps so that the hoses will turn freely and not become twisted. Disconnect the hydraulic hoses at the bottom of the steering control unit. Install plugs at all hose ports and hoses to prevent dirt from entering the system.

10. Remove the capscrews, lockwashers, and lock plates that fasten the steering column to the pivots on the lift truck. Remove the steering column from the lift truck. Make sure the electrical wires and the hydraulic hoses are not damaged as the steering column is removed.

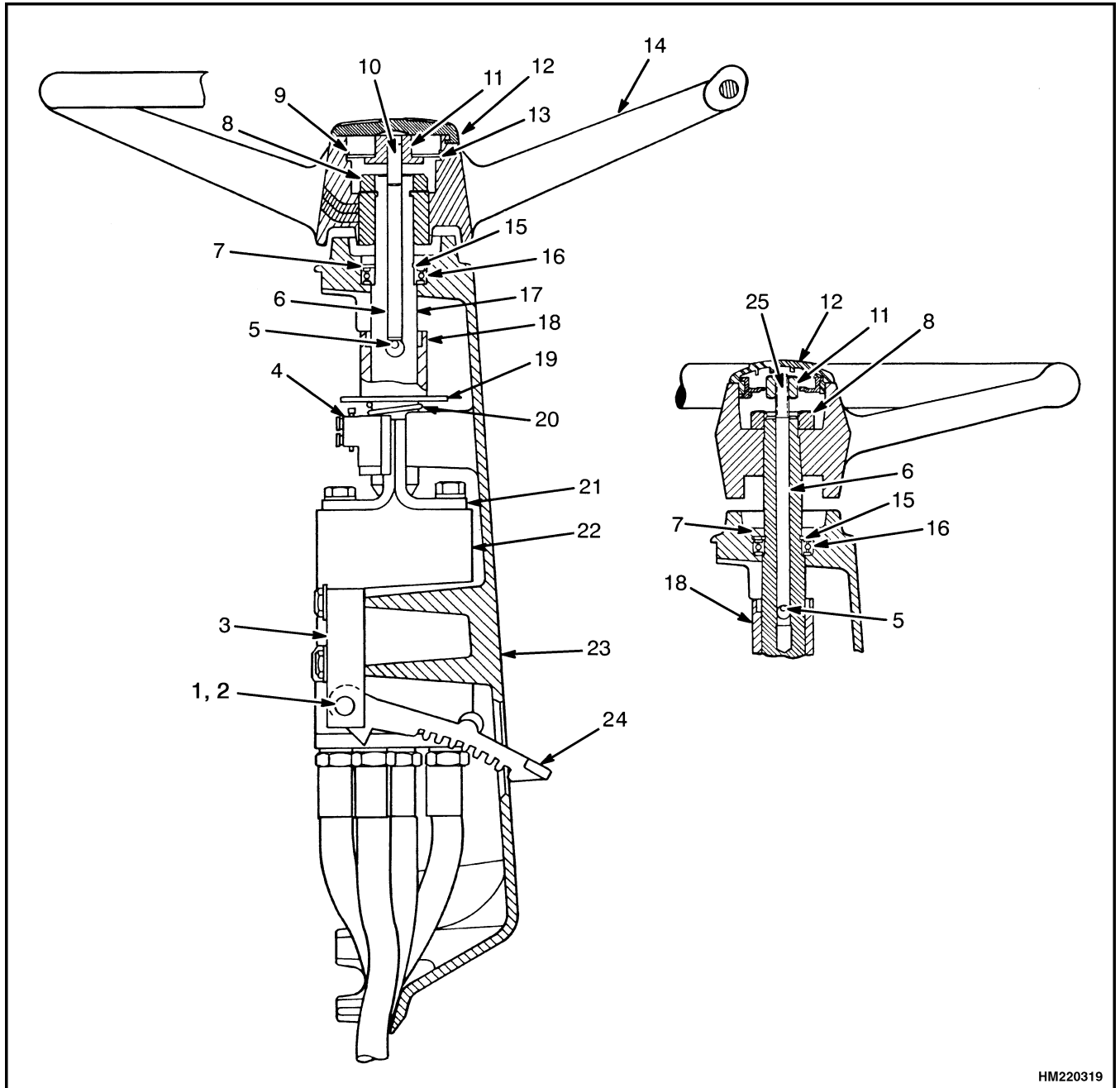

HM220319

NOTE: PETRI STEERING WHEEL SHOWN.

- | | | |
|-----------------------|------------------------|---------------------------|
| 1. LATCH PIVOT PIN | 10. SOCKET HEAD SCREW | 19. PLASTIC WASHER |
| 2. COTTER PIN | 11. ADJUSTER SPOOL NUT | 20. SPRING |
| 3. BRACKET | 12. HORN COVER | 21. BRACKET |
| 4. HORN SWITCH | 13. BASE PLATE | 22. STEERING CONTROL UNIT |
| 5. PIN | 14. STEERING WHEEL | 23. STEERING COLUMN |
| 6. PUSH ROD | 15. EXTERNAL SNAP RING | 24. LATCH |
| 7. INTERNAL SNAP RING | 16. BEARING | 25. SOCKET HEAD SCREW |
| 8. STEERING WHEEL NUT | 17. STEERING SHAFT | |
| 9. LOCK RING | 18. PLASTIC TUBE | |

Figure 5. Steering Wheel and Steering Column Assembly (Later XL Units)

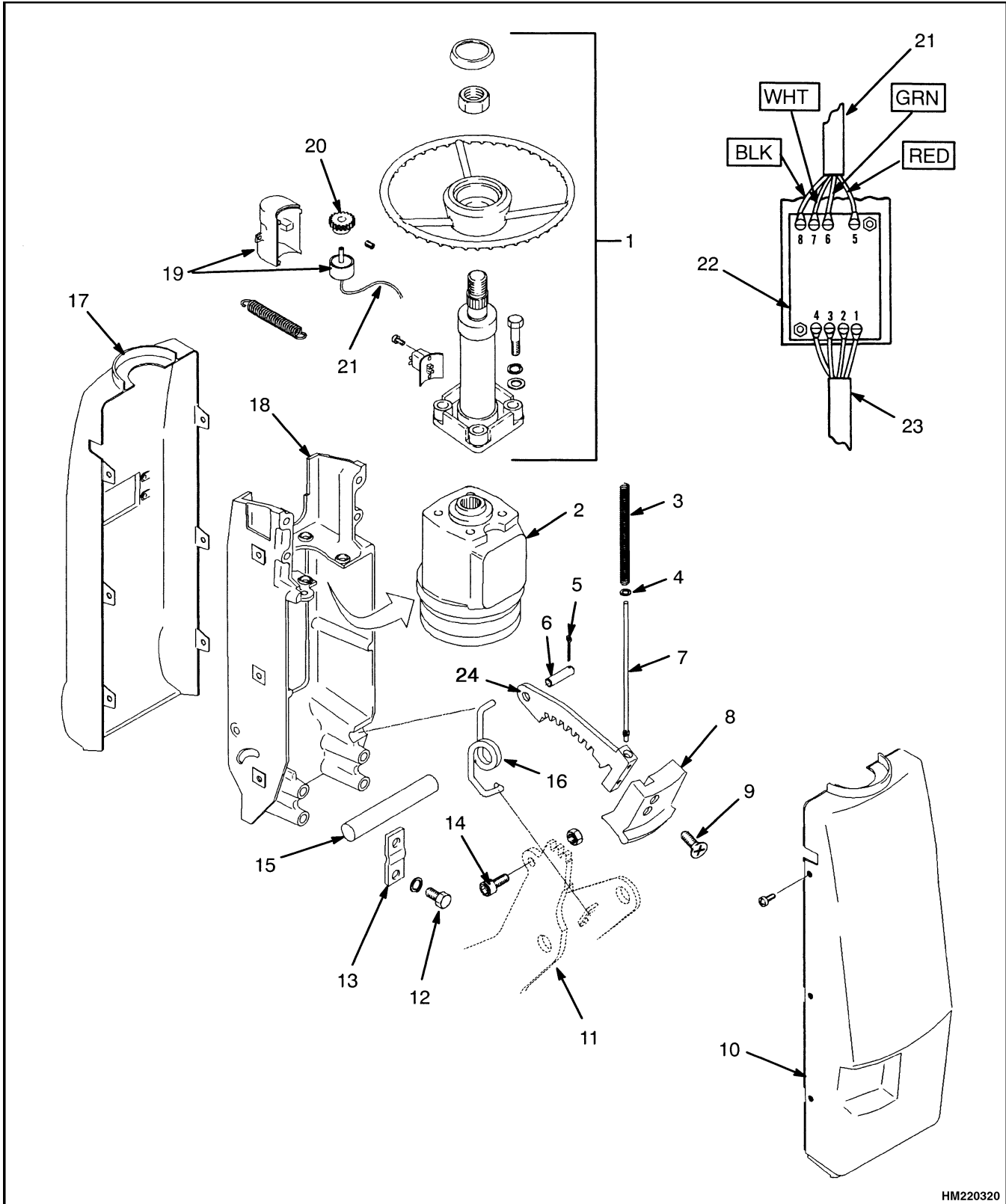
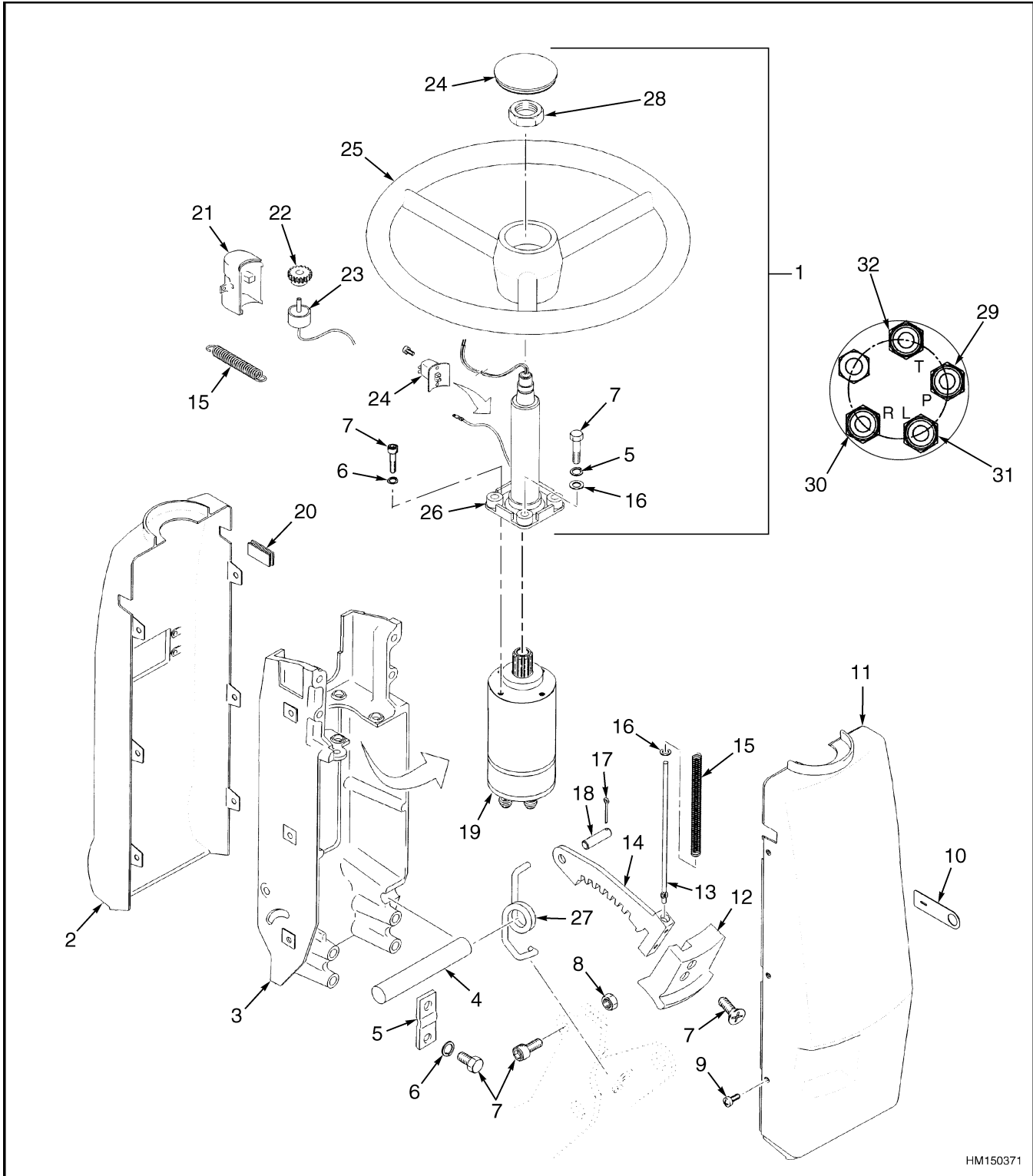

Figure 6. Steering Wheel and Steering Column Assembly (Early Model XM Units)

Legend for Figure 6

NOTE: FOR CORRECT CONNECTION, SEE THE **DIAGRAMS** SRM FOR YOUR LIFT TRUCK.

- | | |
|---|--|
| <ol style="list-style-type: none"> 1. STEERING WHEEL, SHAFT, AND ON-DEMAND STEERING PARTS 2. STEERING CONTROL UNIT 3. SPRING 4. WASHER 5. COTTER PIN 6. PIN 7. PUSH ROD 8. COLUMN TILT LEVER 9. SCREW 10. REAR COVER 11. MOUNT 12. CAPSCREW | <ol style="list-style-type: none"> 13. PLATE 14. ALLEN HEAD CAPSCREW 15. PIVOT SHAFT 16. RETURN SPRING 17. FRONT COVER 18. BRACKET 19. OPTICAL ENCODER AND BRACKET 20. DRIVE GEAR AND SETSCREW 21. ENCODER/ACTIVATOR WIRE HARNESS 22. ACTIVATOR (UNDER INSTRUMENT PANEL TO LEFT OF STEERING COLUMN) 23. TRUCK WIRE HARNESS 24. LATCH |
|---|--|
-
11. Remove the steering shaft as follows:
 - a. Move the plastic tube and washer toward the steering control unit and compress the spring for the horn switch. Then remove the pin that goes through the steering shaft and engages the plastic tube.
 - b. Remove the external snap ring that holds the bearing in the steering column. On units that have On-Demand steering, loosen the setscrew in the gear on the shaft. The return spring, washer, and tube are removed at the same time as the steering shaft and bearing are removed. Use a small pry bar at the bottom of the steering shaft near the steering control unit to remove the steering shaft and bearing (also, return spring, washer, and tube) from the steering column.
 12. Remove the two capscrews that hold the steering control unit and the bracket to the steering column. Remove the four capscrews or nuts that fasten the steering control unit to the bracket.
- ASSEMBLY COMPONENTS, INSTALL**
- NOTE:** This procedure is for the installation of all components of the steering column assembly. Usually it is not necessary to install all of the components. Do only those steps of the procedure necessary to install the component you need to install.
1. Install the steering column on the cowl mounts. Lubricate the pivots with multipurpose grease and install the capscrews into the housing.
 2. Fasten the two halves of the mount bracket to the steering control unit. Make sure to install bracket for activator if the activator is in the steering column. Install the steering control unit assembly into the steering column. Make sure to install the horn switch and the switch bracket as well as the two wire clamps on the same mount capscrews.
 3. For early model lift trucks, if the instrument display panel or instrument display meters and gauges were removed, install them. See the service manual sections **Instrument Cluster**, **Instrument Panel Indicators and Senders** or **Electrical System** for your lift truck model for the installation procedures.
 4. For later model lift trucks, if the display panel was removed, install it and connect all plugs to the display panel.
 5. If removed, install the wires on the key switch as identified during removal. Install the key switch.
 6. If removed, install the wires on the direction switch as identified during removal. Install the direction switch in the housing and install the large nut, boot, and handle.



HM150371

Figure 7. Steering Wheel and Steering Column Assembly (Later Model XM Units)

Legend for Figure 7

- | | |
|----------------------------------|---|
| 1. ON-DEMAND STEERING COMPONENTS | 17. COTTER PIN |
| 2. FRONT COVER | 18. PIN |
| 3. BRACKET | 19. STEERING CONTROL UNIT |
| 4. PIVOT (STEERING) SHAFT | 20. PLUG (WITHOUT TURN SIGNAL) |
| 5. PLATE | 21. OPTICAL ENCODER HOUSING AND BRACKET |
| 6. LOCKWASHER | 22. DRIVE GEAR AND SETSCREW |
| 7. CAPSCREW | 23. OPTICAL ENCODER |
| 8. LOCK NUT | 24. HORN SYSTEM |
| 9. SCREW | 25. STEERING WHEEL |
| 10. STATIC GROUND PATCH | 26. STEERING COLUMN |
| 11. REAR COVER | 27. RETURN SPRING |
| 12. COLUMN TILT LEVER | 28. LARGE HEX NUT |
| 13. PUSH ROD | 29. INPUT |
| 14. LATCH | 30. RIGHT TURN |
| 15. SPRING | 31. LEFT TURN |
| 16. WASHER | 32. RETURN |

7. Install the bearing on the steering shaft. The seal of the bearing must be toward the steering wheel. Install the snap ring in the groove on the steering shaft.
8. Put the steering shaft through the opening for the bearing in the steering housing. Install the gear for On-Demand steering onto the steering shaft. Install the pin that holds the plastic tube and flange for the horn switch. Install the plastic tube, the plastic flange, and the spring onto the steering shaft. Push the steering shaft into the splines or align the tang of the steering control unit. Install the snap ring that holds the bearing in the steering housing.
9. If removed, install the optical encoder and bracket assembly on the column housing. Make sure the pinion gear of the optical encoder and the drive gear on the steering shaft are correctly aligned. Tighten the setscrew for the drive gear. Install the wires on the activator as identified during removal. The correct connections are also shown in Figure 4, and Figure 6. Install the activator on the bracket fastened to the steering control unit.
10. Install the steering wheel. Install the large hex nut onto the steering shaft. Install the push rod and adjuster spool into the steering shaft. Install the base plate (not part of Petri steering wheel), the lock ring, and the horn cover.

**WARNING**

The hydraulic hoses MUST be connected to the correct ports and fittings, or the steering system will not operate as expected. This operation that is not expected can cause damage or personal injury. Connect the hoses as identified during removal.

11. Connect the hydraulic hoses to the steering control unit, the cowl, the control valve, or the steering pump as removed during removal. Make sure each hydraulic hose is connected to the correct ports or fittings as identified during removal.
12. Connect the wire connectors at the bottom of the steering column. Install the access cover on the steering column.

Power Steering Motor and Pump

DESCRIPTION

NOTE: See the section **Hydraulic System** for your lift truck model for additional information on the power steering pump.

The power steering motor and pump assembly is under the floor plate on all units except the J2.00-3.20XM (J40-60XM, J40-60XM₂), E1.50-2.00XMS (E25-40XMS, E25-40XM₂S), and E3.50-5.50XL (E70-120XL, E70-120XL₃) units. The

E1.50-2.00XMS (E25-40XMS, E25-40XM₂S) and the E3.50-5.50XL (E70-120XL, E70-120XL₃) units have the motor and pump assembly under the battery compartment. The J2.00-3.20XM (J40-60XM, J40-60XM₂) units have the motor and pump assembly mounted behind the battery compartment. The power steering motor and pump operate as described in Description in front part of this manual. See Figure 8, Figure 9, and Figure 10.

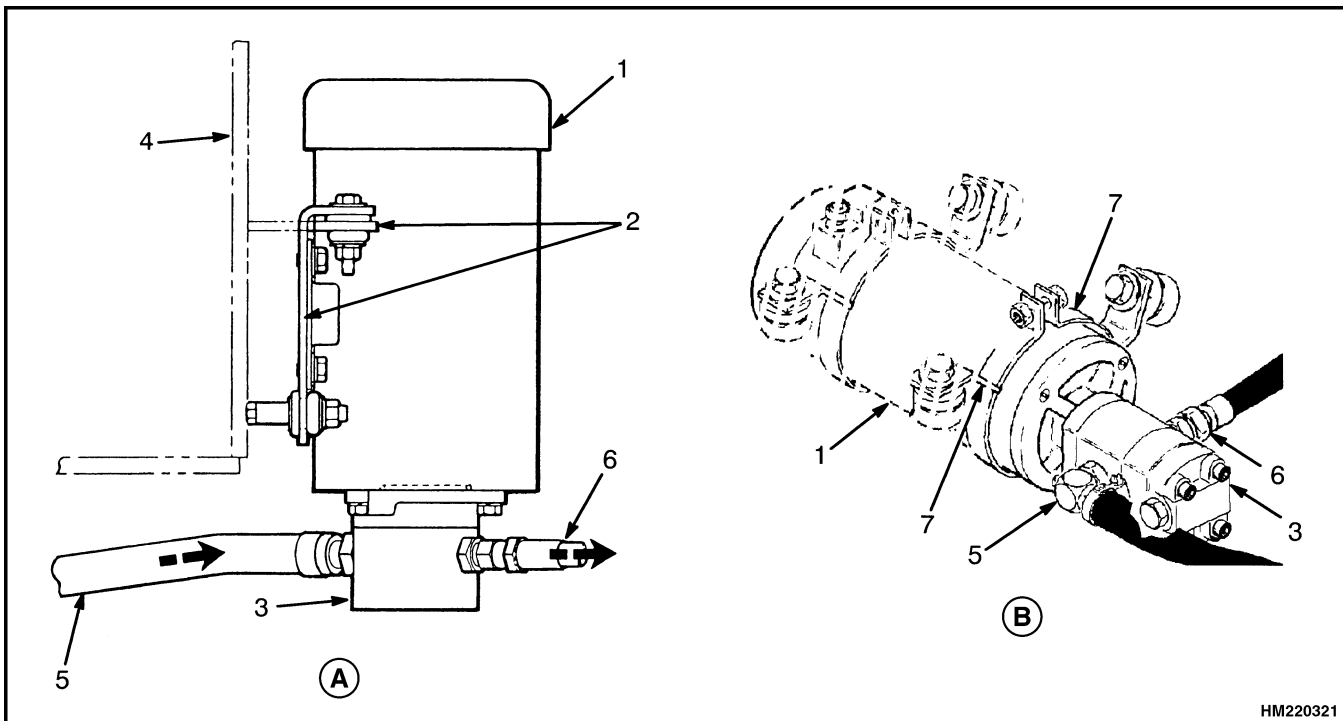

A. E1.25-3.00XL (E25-60XL), J2.00-3.00XL (J40-60XL), E2.00-3.20XM (E45-65XM, E45-65XM₂), N30XMH, N30XM₂H AND E3.50-5.50XL (E70-120XL, XL₃)

B. A1.00-1.50XL (A20-30XL)

1. POWER STEERING MOTOR
2. CLAMP MOUNT AND BRACKET
3. POWER STEERING PUMP
4. LIFT TRUCK FRAME

5. FROM HYDRAULIC TANK
6. TO STEERING CONTROL UNIT
7. STRAP AND MOUNT BRACKET

Figure 8. Power Steering Motor and Pump

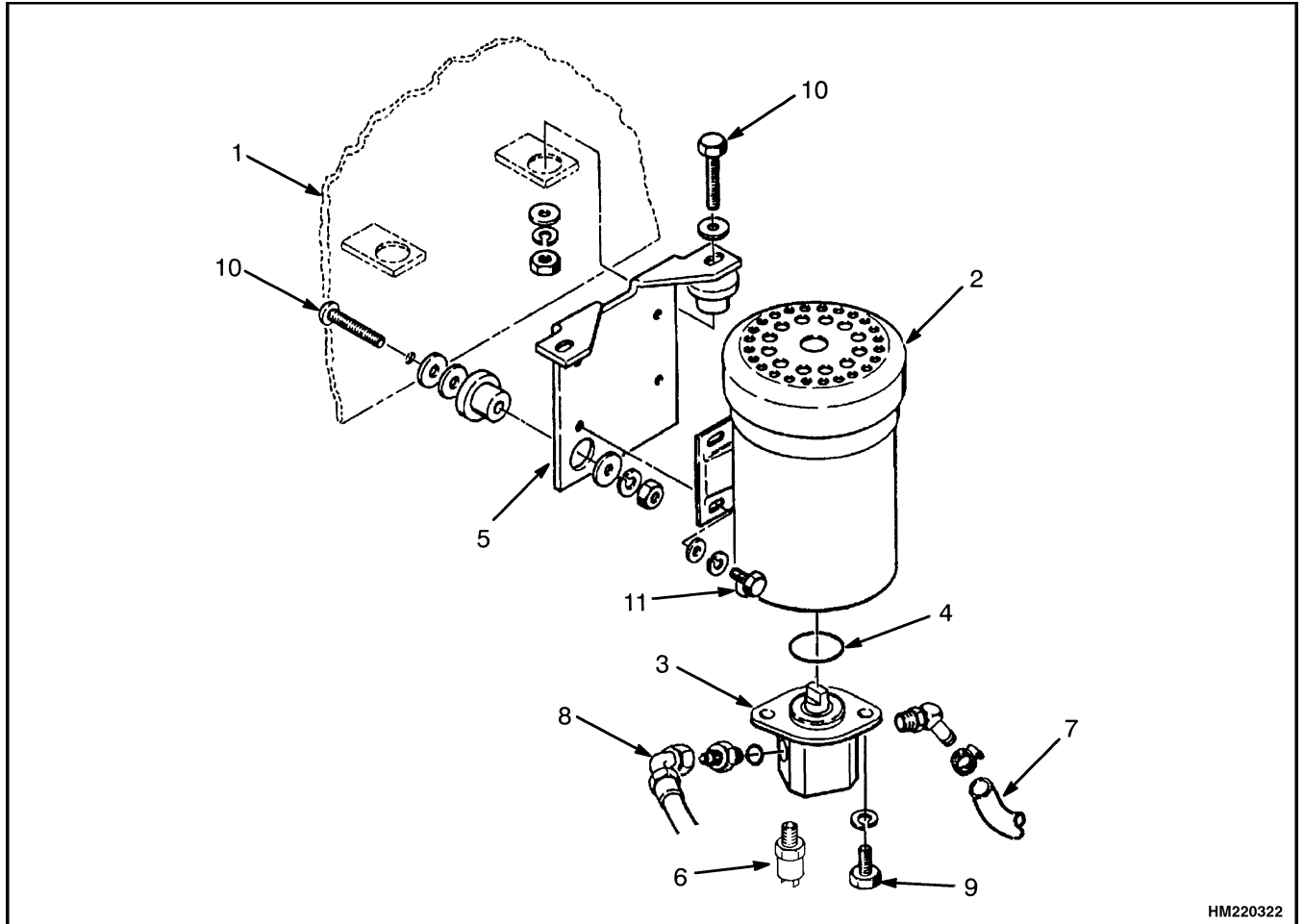

HM220322

- | | |
|---------------------|-----------------------------|
| 1. LIFT TRUCK FRAME | 7. FROM HYDRAULIC TANK |
| 2. STEERING MOTOR | 8. TO STEERING CONTROL UNIT |
| 3. STEERING PUMP | 9. PUMP MOUNTING BOLT |
| 4. O-RING | 10. BRACKET MOUNTING BOLT |
| 5. MOUNTING BRACKET | 11. MOTOR MOUNTING BOLT |
| 6. PRESSURE SWITCH | |

Figure 9. Power Steering Motor and Pump J2.00-3.20XM (J40-60XM, J40-60XM₂)

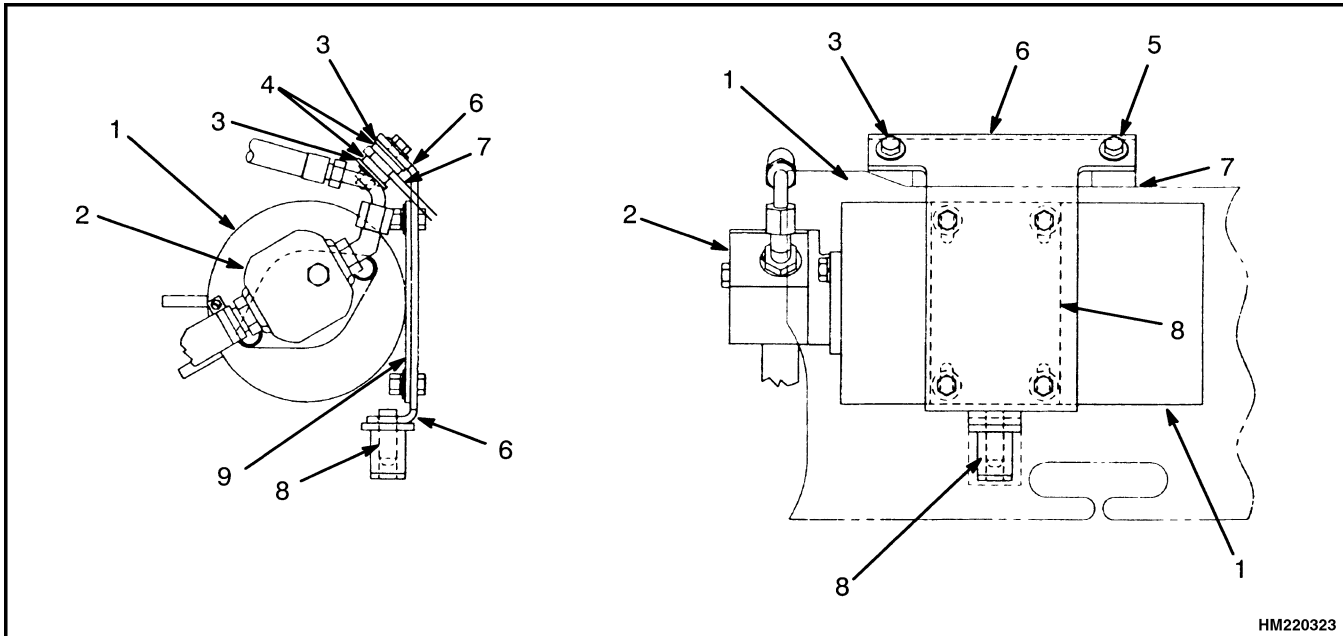

1. MOTOR
2. HYDRAULIC PUMP - STEERING
3. WASHER
4. RUBBER BUSHINGS
5. CAPSCREW AND NUT

6. MOUNT BRACKET
7. FRAME BRACKET
8. MOUNT PIN
9. MOTOR BASE

Figure 10. Power Steering Pump Motor E1.50-2.00XMS (E25-40XMS, E25-40XM₂S)

REMOVE AND DISASSEMBLE, MODELS E1.25-3.00XL (E25-60XL), J2.00-3.00XL (J40-60XL), E2.00-3.20XM (E45-65XM, E45-65XM₂), N30XMH, AND N30XM₂H,

NOTE: On some units, the power steering motor must be removed from the mounts on the frame to replace the brushes. Other motors require removal of the end bell to replace the brushes.

1. Disconnect the battery and attach a tag on the truck battery connector, stating **DO NOT CONNECT BATTERY**.
2. Remove the floor plate.
3. Install identification tags on the power cables and disconnect them from the power steering motor.
4. Attach identification tags on the electrical wires and disconnect them from the pressure switch.
5. Put a drain pan under the pump. Install identification tags on the hydraulic hoses and disconnect them from the power steering pump. See Figure 8. Quickly put plugs in the ends of the hoses and the pump ports to keep oil from draining and dirt from entering the system.
6. Remove the two clamp capscrews and nuts, the washers, and the two mounts. Remove the motor, pump, and bracket as an assembly. See Figure 8.
7. Check the motor brushes. See the sections **Periodic Maintenance** (for your truck model) and **DC Motor Maintenance** 620 SRM 294 for additional information for inspection of the brushes and commutator.
8. If the motor must be disassembled for cleaning or repairs, remove the pump so that a new oil seal can be installed. Before disassembling the motor, make match marks for alignment on the end plates and the motor housing. These marks are necessary to assemble the motor correctly. To disassemble the motor, see Figure 8, Figure 11, and Figure 12.

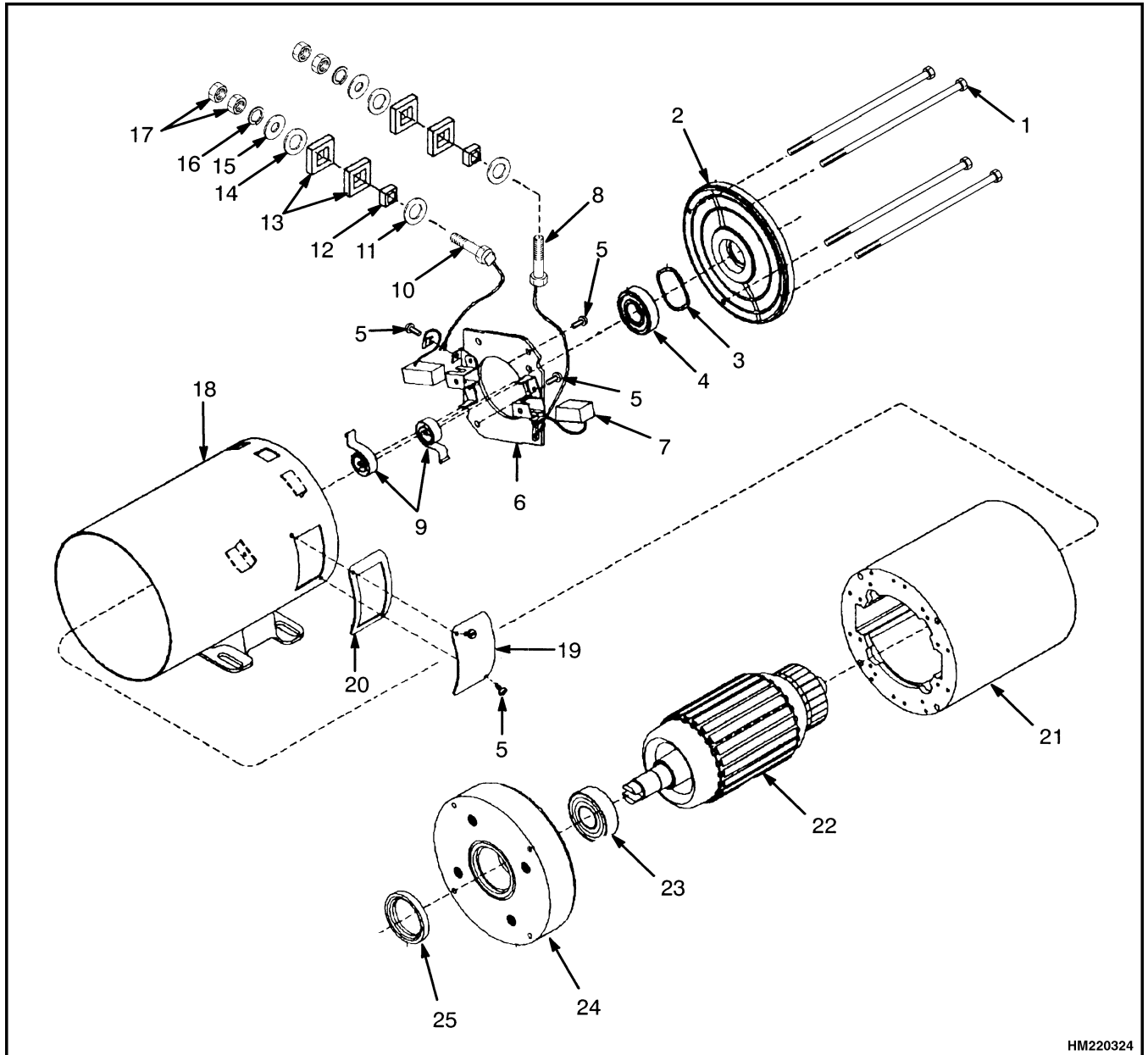

HM220324

- | | |
|-----------------------------|----------------------|
| 1. THROUGH BOLT | 14. INSULATOR WASHER |
| 2. END PLATE | 15. WASHER |
| 3. SPRING WASHER | 16. WASHER |
| 4. BEARING | 17. NUT |
| 5. BRUSH HOLDER MOUNT SCREW | 18. STATOR |
| 6. BRUSH HOLDER ASSEMBLY | 19. COVER |
| 7. BRUSH | 20. GASKET |
| 8. TERMINAL AND WIRE | 21. CORE |
| 9. BRUSH SPRING | 22. ARMATURE |
| 10. TERMINAL AND WIRE | 23. BALL BEARING |
| 11. INSULATOR WASHER | 24. END PLATE |
| 12. BUSHING | 25. SHAFT SEAL |
| 13. SPACER | |

Figure 11. Power Steering Pump Motor E/J1.50-3.20XM (E/J25-65XM, E/J25-65XM₂), N30XMH and N30XM₂H